

driveTM

www.drivemedical.com

Rev.3.10.27.15

bariatric battery
powered lift
with four point cradle

item # 13244



EU Authorized Representative
Drive Medical LTD
Ainley's Industrial Estate
Elland, West Yorkshire,
United Kingdom HX5 9JP

www.drivemedical.com

driveTM

instructions

WEIGHT CAPACITY: 600 LBS (272 KG)

The Bariatric Electric Patient Lift is designed to allow an attendant to ergonomically transfer a patient from one resting position to another. It is not a transport device. Use a sling that is recommended by the individual's physician. During transfer, with patient suspended in a sling to the lift, do not roll caster base over objects such as raised carpet bindings, door frames, or any uneven surfaces that would create an imbalance of the lift. Use steering handles at all times to maneuver the lift.

installation

1. The Electric Patient Lift is packed in one carton which contains the following components:
 - A. Mast with boom including Drive Jumbo Actuator
 - B. Base
 - C. Base spreading adjustment handle.
 - D. Battery box, control box and control handset.
 - E. "U" shaped push handle
 - F. 4 point cradle
2. Installation Procedure: (please refer to figure 1)
 - A. Remove the screws (#12) from the base as indicated.
 - B. With the boom pointed in the same direction as the base legs, insert the mast (#2) into mast sleeve and ensure the mast is in place.
 - C. Install the screw (#12) on to the mast (#2) through mast sleeve.
 - D. Install the push handles (#15) into the reserved position of the mast (#2) and ensure the screws on the push handles are screwed on the mast tightly.
 - E. Remove the black colored screw from the mounting bracket (#8) located on the right side of the mast (#2).
 - F. Mount the control box (#4) on the bracket (#8) and screw back the bolts on the bottom of the bracket.
 - G. Place and clip the battery pack (#7) on the top of the bracket.

- H. Insert the base spreading adjusting handle (#3) into the socket located behind the mast sleeve.
- I. Attach the cradle (#10) to the end of the boom and make sure the bolts are screwed tightly.
- J. The Bariatric Electric Patient Lift is now ready to operate.

FIGURE 1

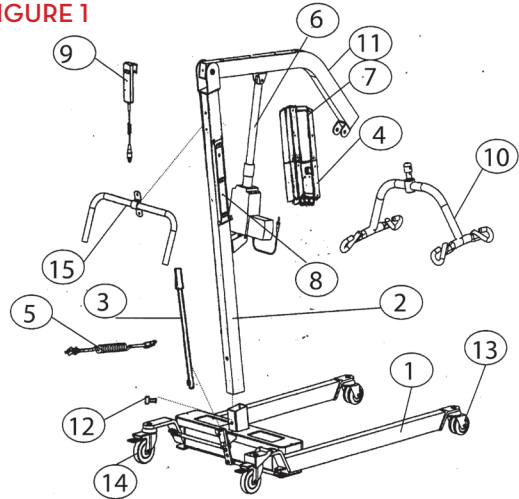

PART#	DESCRIPTION	QTY
1	Base Assembly	1
2	Mast	1
3	Spreading Adjustment Handle	1
4	Linak Control Box	1
5	Power Cord	1
6	Linak Acuator	1
7	Battery Pack	1
8	Mounting Bracket	1
9	Hand Set	1
10	4-Point Cradle	1
11	Boom	1
12	Hexagon Screw (12x20mm)	1
13	3" Twin Caster	2
14	4" Braked Caster	2
15	"U" Shaped Push Handle	1

It is extremely important that the lift be inspected before each use. The following items need to be checked:

- a. All nuts and bolts should be tight.
- b. The lifter should move freely with caster brakes off.
- c. Check the brakes on the rear casters for proper operation.
- d. Make sure base adjustment mechanism is operating easily.
- e. Double check to ensure the “U” bracket at the end of the boom and the “S” hook on the hanging bar are secured tightly.
- f. Work the Actuator to ensure that the battery still has enough power. When the battery is 50% below full capacity, it will give a “beep” warning and will need to be re-charged immediately.
- g. Before initial use, place a drop of oil on the following areas:
 1. Where mast and boom connect, hanging bar hook, pump handle hinge, and caster axles.
 2. Where pump and boom attach.
 3. Lubricate above mentioned every 2 to 3 months.

how to operate the electric patient lift:

1. Spread the base legs to the widest position before lifting.
2. Keep the patient centered between the base legs and have the patient face the attendant.
3. Be extremely cautious and use restraint straps for spastic or severely handicapped patients.
4. How to use Standard or Commode Slings.
 - a. For smooth and easy lifting, have the lift, chains, sling, commode or wheelchair in ready position.
 - b. With the patient in the center of the bed, roll patient on side away from the attendant.
 - c. Roll the patient on side toward the attendant and center the patient on sling. With the base of lifter under bed, press the down button on the control handset to lower the boom (#11).

- d. Hook the hanging strips with the hanging bar. If a chain is used, make sure the “S” hooks are away from the patient.
- e. Lift the patient by pressing the UP button on the Control Handset. DO NOT lock the casters of the Patient lift when lifting an individual. Casters MUST be left unlocked to allow Patient Lift to stabilize during the lifting procedure.
- f. Lift patient until his/her feet will swing easily off the bed keeping patient facing the attendant.
- g. Transfer patient to the wheelchair or commode and position above seat surface. Lock brakes of both lifter and commode or wheelchair.
- h. Press the down button on control handset to gradually lower the patient.
- i. During the descent, assist patient to attain correct sitting posture.
- j. For transferring to wheelchair, when patient is seated, push down on boom to slacken hanging strips of sling. Patient can remain seated in sling.
- k. For commode use, adjust clothing before moving lift to straddle commode. Keep hanging strips taut and make sure patient is in a comfortable position.

important safety instructions:

1. Patient lifter is a transfer device that allows patient attendant to transfer patients from bed to wheelchair or commode...etc. It should not be used to transport patients.
2. When lifting the patient, make sure the base legs are in the most widely opened position. DO NOT lock the casters of the Patient lift when lifting an individual. Casters MUST be left unlocked to allow Patient Lift to stabilize during the lifting procedure.
3. When battery power goes below 50%, the controller has an audible “beep” warning. When the low battery warning is heard, charge the battery immediately. Please note that a lifted patient cannot be lowered down when battery is out of power.
4. Push the “emergency” red button if the control unit system is not functioning properly.

5. “Quick Release” system (push/pull) enables stepless retraction of the actuator under load (mechanical emergency lowering). Refer to figure 2.
6. How to charge: (please refer to figure 3)
 - a. With the battery box, control box and actuator assembled, insert the power cord plug in control box and other end to a wall outlet.
 - b. The battery is charging when the “charge” light is illuminated.
 - c. When the battery charge is completed, the “charge” light will shut off automatically (on average, it takes approximately 4 hours to charge from 50% to 100% capacity).
 - d. Remove the power supply cord.
 - e. The lift is now operational.

FIGURE 2

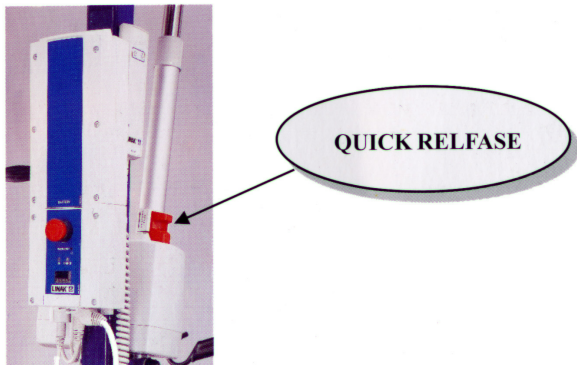
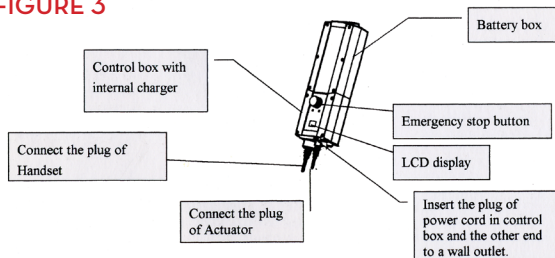

FIGURE 3



lifetime limited warranty

Your Drive branded product is warrantied to be free of defects in materials and workmanship for the lifetime of the product for the original consumer purchaser.

This device was built to exacting standards and carefully inspected prior to shipment. This Lifetime Limited Warranty is an expression of our confidence in the materials and workmanship of our products and our assurance to the consumer of years of dependable service.

This warranty does not cover device failure due to owner misuse or negligence, or normal wear and tear. The warranty does not extend to non-durable components, such as rubber accessories, casters, and grips, which are subject to normal wear and need periodic replacement.

If you have a question about your Drive device or this warranty, please contact an authorized Drive dealer.

© 2015 Medical Depot, Inc. All rights reserved.
 Drive is a trademark of Medical Depot, Inc.
 Port Washington, N.Y. 11050 USA Made in China